

Features

- ▶ Advanced, Catalog Speech Processor for High-Quality Sound, Capable of Unlimited Speech Duration Using External Memory
- ▶ Operates up to 12.32 MIPS.
- ▶ Supports High-Quality Algorithms Such as MX (1.0 Kbps – 3.5 Kbps at 8 kHz), CX (3.0 Kbps – 11.2 kHz at 8 kHz Sampling Rate), ADPCM, Single Channel FM with CX or MX.
- ▶ Speed and Pitch Shifting in MX for Various Voice Effects.
- ▶ Six Level Digital Gain Control.
- ▶ 4 User Configurable I/O's.
- ▶ Very Low-Power Operation, Ideal for Hand-Held Devices.
- ▶ Low-Voltage Operation, Sustainable by Three (3) Batteries.
- ▶ Three Reduced Power Standby Modes, Less Than 10 μ A in Deep-Sleep Mode.
- ▶ Resistor-Trimmed Oscillator or 32.768 kHz Crystal Reference Oscillator.
- ▶ Direct Speaker Drive, 32 Ω (PDM).
- ▶ Interrupt Driven, 4 or 8-Bit Parallel Data Transfer Protocol.
- ▶ Available in Die Form or 64-Pin LQFP Package

Description

The SC-691 is a standard slave synthesizer from Sensory, Inc. that accepts compressed speech data from other microprocessors or microcontrollers and converts it to speech.

This allows the SC-691 to be used with a master microprocessor/microcontroller in various speech-related products such as security systems, learning aids, games, and toys. High quality, low bit-rate coders, easy interface with the master microcontroller, digital gain control, low power sleep mode, and low voltage operation makes this device ideal for products requiring long duration speech, less development cycle times, and peripheral device control through the slave device.

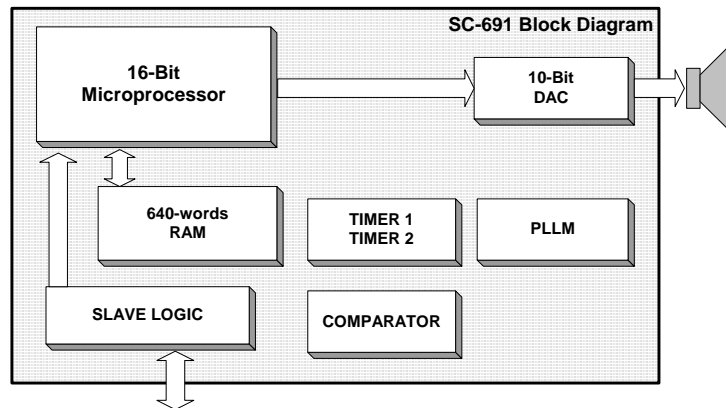

This device supports several speech synthesis algorithms that permit tradeoffs to meet the price performance requirements of various markets.

The SC-691 implements a unique feature of playing a single channel FM music along with CX or MX speech data concurrently. This feature allows the user to speak a certain phrase in MX or CX with single channel music in the background.

The SC-691 is optimized to support a 4-bit wide data transfer protocol. The device has two status bits and three control bits that control the communication protocol between the master and the slave.

The SC-691 also has 1 bit (command/data) which differentiates between a command and speech data feeding into the slave. In 4-bit mode, various commands are sent to the slave during speech to perform various tasks.

The SC-691 also supports the 8-bit wide data transfer but the support for commands is disabled during speaking-a-phrase. When speaking-a-phrase in 8-bit mode is complete, the SC-691 switches back to the 4-bit mode to receive the next command. Switching between 4 bit mode and 8 bit mode is permitted between speech data files.

Functional Block Diagram

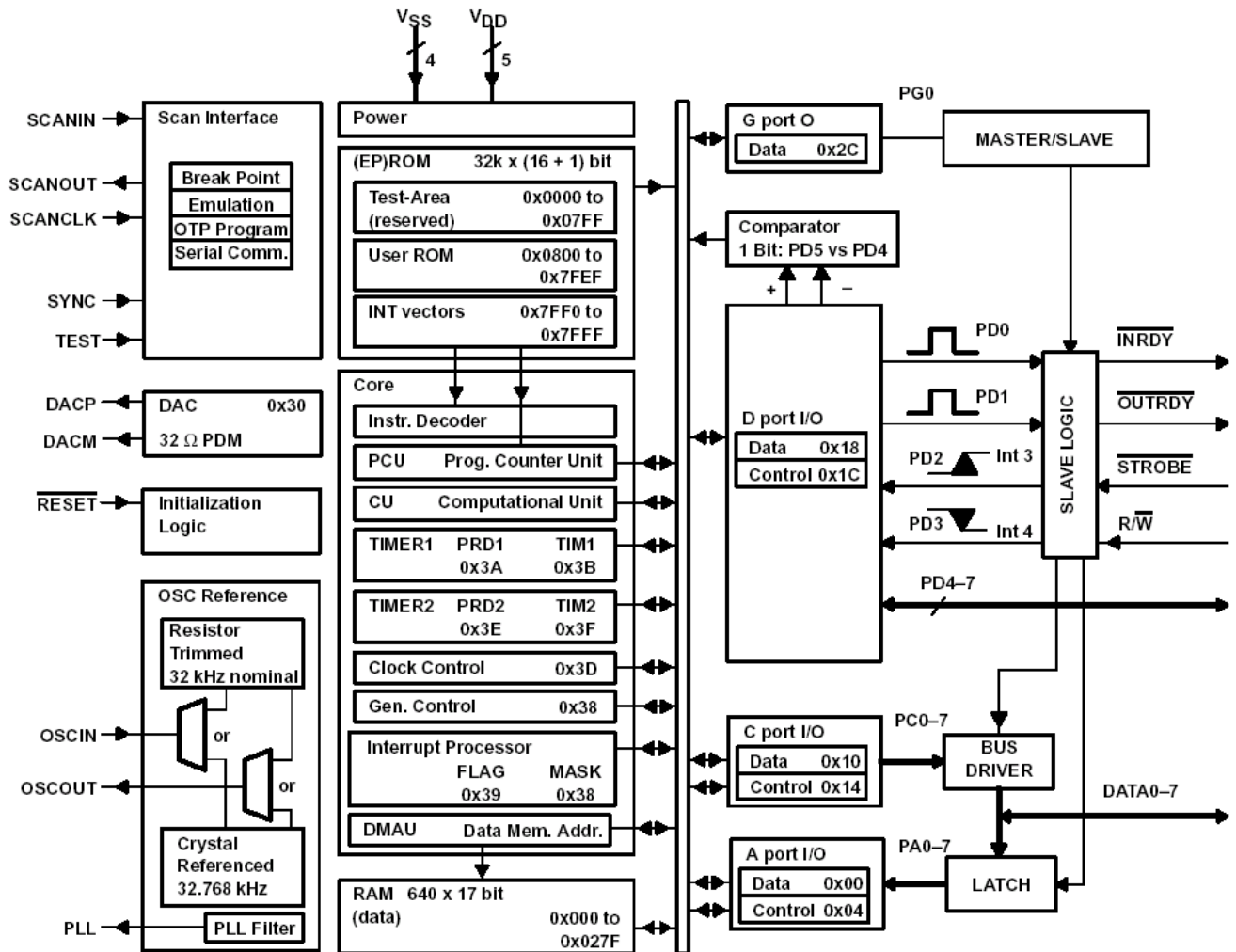

Pin/Pad Assignments

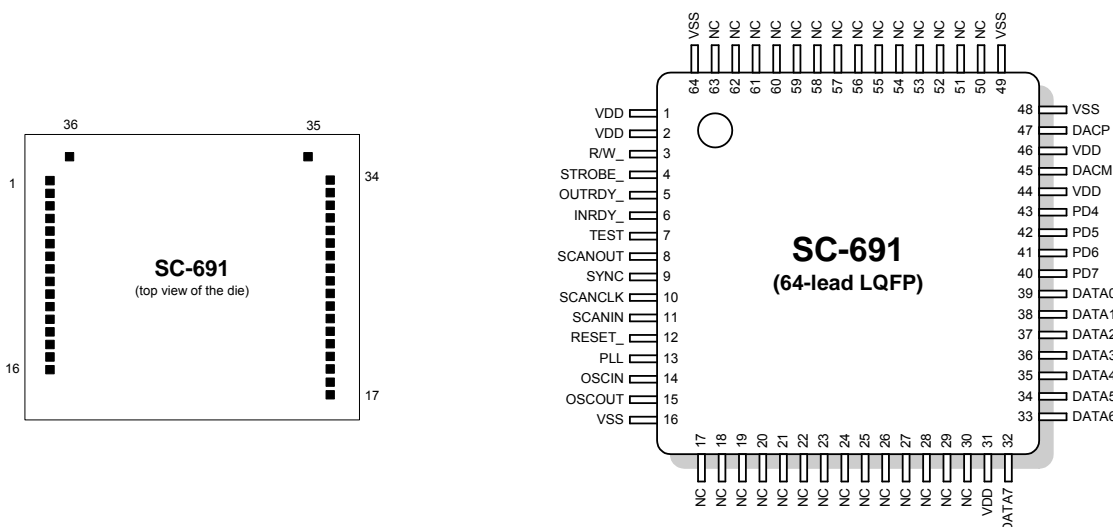

NAME	PIN NO.	PAD NO.	I/O	DESCRIPTION
DATA0–DATA3	11 → 7	25 → 22	I/O	Data bits 0 through 3 (in 4-bit or 8-bit mode)
DATA4 or DATA/COMMAND	8	21	I/O	Data bit 4 (in 8-bit mode) NOTE: Pin 8 is DATA4 in 8-bit mode, or DATA/COMMAND in 4-bit mode.
DATA5–DATA7	34 → 32	20 → 18	I/O	Data bits 5 through 7 (8-bit mode only)
INRDY_	6	6	O	An output signal from the slave to the microcontroller. A low signal indicates that the SC-691 is ready to accept data or command. A high signal indicates that the SC-691 is busy and the microcontroller must not write any data or command to it
OUTRDY_	5	5	O	An output signal from the slave to the microcontroller. A low signal indicates that the SC-691 is ready to send data or command to the microcontroller.
PD4–PD7	43 → 40	29 → 26	I/O	General-purpose I/O bus
R/W_	3	3	I	An input signal to the slave from the microcontroller. Read/write select signal which is set high for read operations or set low for write operations by the microcontroller.
STROBE_	4	4	I	An input signal to the slave from the microcontroller. STROBE_ sequences read or write operations in conjunction with the R/W_ signal. This signal is pulsed high-low-high for read or write operations sequencing.
Reference Oscillator Signals				
OSCOUT	15	15	O	Output of resistor/crystal oscillator
OSCIN	14	14	I	Input to resistor/crystal oscillator
PLL	13	13	O	Output of phase-lock-loop filter
Scan Port Control Signals				
SCANIN [†]	11	11	I	Scan port data input
SCANOUT	8	8	O	Scan port data output
SCANCLK	10	10	I	Scan port clock
SYNC [†]	9	9	I	Scan port synchronization
TEST [†]	7	7	I	Test modes
Digital-to-Analog Sound Output				
DACP	47	33	O	Digital-to-analog plus output (+)
DACM	45	31	O	Digital-to-analog minus output(-)
Initialization				
RESET_	12	12	I	Device initialization
Power Signals				
V _{DD}	1, 2, 31, 44, 46 [‡]	1, 2, 17, 30, 32 [‡]	-	Processor power, 5 V nominal supply voltage
V _{SS}	16, 48, 49 [‡] , 64	16, 34 [‡] , 8, 7	-	Ground pin

[†] All pins must be N.C.

[‡] Marked pins are V_{DD} and V_{SS} connections which service the DAC circuitry. These pins tend to sustain a higher current draw. A dedicated decoupling capacitor across these pins is therefore required.

	SC-691 (4-bit mode)	SC-691 (8-bit mode)
Number of data lines	4	8
Number of control lines	3 (STROBE_, R/W_, data/command)	2 (STROBE_, R/W_)
Number of status lines	2 (INRDY_, OUTRDY_)	2 (INRDY_, OUTRDY_)
Number of general-purpose I/O lines	4	4
Support for commands (while speaking)	Yes	No

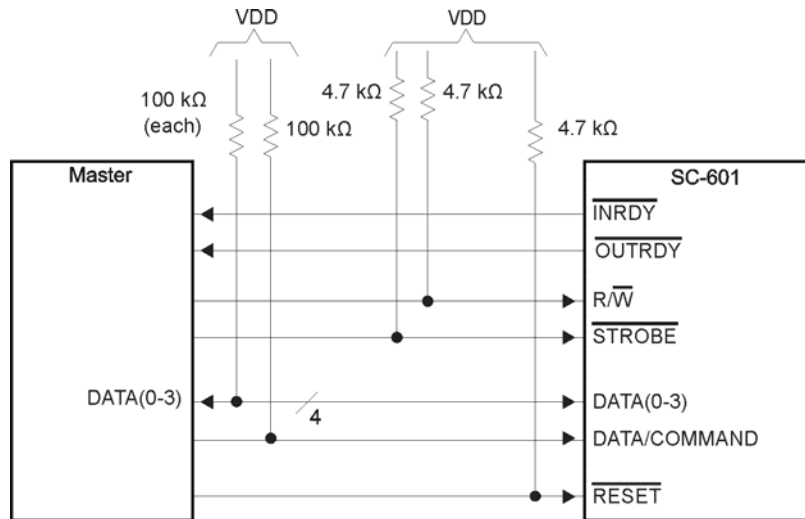

Figure 1: Interfacing Diagram 4-Bit Mode

Note:

- STROBE_ Active low STROBE_ signal from microcontroller
- R/W_ Read/write signal from microcontroller
- RESET_ Active low RESET_ signal from microcontroller
- DATA0-3 DATA3 Data bits 0 through 3
- PD4-PD7 General-purpose I/O bus
- DACP Output to speaker/amplifier
- DACM Output to speaker/amplifier
- DATA/COMMAND This bit determines if the data sent by the microcontroller is data or command.

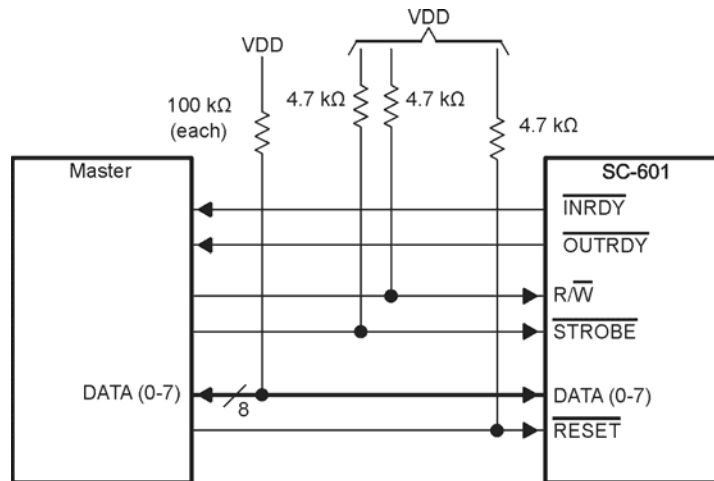

Figure 2: Interfacing Diagram 8-Bit Mode

Note:

- STROBE_ Active low STROBE_ signal from microcontroller
- R/W_ Read/write signal from microcontroller
- RESET_ Active low RESET_ signal from microcontroller.
- INRDY_ Active low indicates that the SC-691 is ready to accept data.
- OUTRDY_ Active low indicates that the SC-691 is ready to send data.
- DATA0-DATA7 Data bits 0 through 7
- PD4-PD7 General-purpose I/O bus
- DACP Output to speaker/amplifier
- DACM Output to speaker/amplifier

Read Operation By The Master

The process for the read operation by the master is the same in either 4-bit or 8-bit mode. The read operation by the master happens when the slave wants to send something to the master. The read process is initiated by the slave by pulling OUTRDY_ low when it is ready.

The following events take place during the read operation:

- ▶ The SC-691 puts the data to be sent to the master on the internal bus.
- ▶ The SC-691 sets OUTRDY_ low to indicate that it is ready to send data to the microcontroller.
- ▶ The microcontroller sets R/W_ high to indicate a read operation.
- ▶ The microcontroller sets STROBE_ low. The data is available on the external data-bus at this point.
- ▶ The microcontroller reads the data from the bus.
- ▶ The microcontroller sets STROBE_ high. The SC-691 also pulls OUTRDY_ high at the rising edge of STROBE_.
- ▶ The data is taken from the external data-bus after STROBE_ goes high.

The microcontroller should latch or read in the data while STROBE is low. When the microcontroller sets STROBE_ high, the SC-691 sets OUTRDY_ high to indicate that the data has been successfully transferred.

A) Sequence of events for a single read operation:

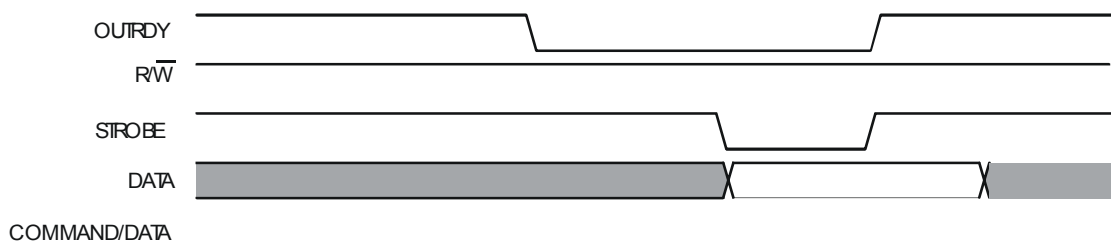

B) Read-Two speech data transfer sequences:

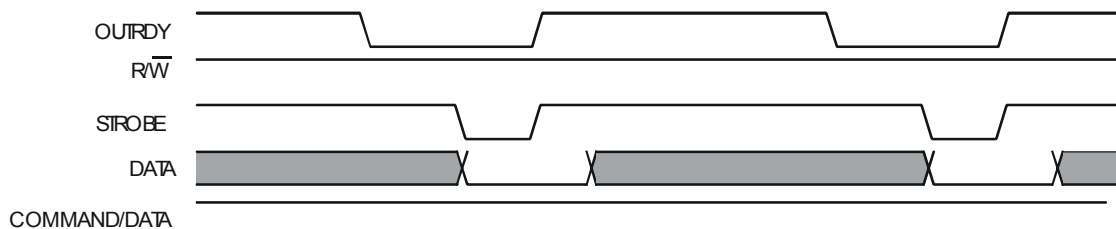

Figure 3: Data Transfer – Read

Write Operation By The Master

The process for the write operation by the master is the same in either 4-bit or 8-bit mode. The write operation by the master happens when the slave is ready to request data or command from the master. The write process is initiated by the slave by pulling INRDY_ low when the slave is ready to receive data. The following events take place during the write operation:

- ▶ The SC-691 sets INRDY_ low to indicate that it is ready to receive data from the microcontroller.
- ▶ The microcontroller sets R/W_ low to indicate a write operation.
- ▶ The microcontroller puts the data in the external data-bus.
- ▶ The microcontroller sets STROBE_ low after the data is valid.
- ▶ The microcontroller sets STROBE_ high after a minimum of 300 ns. The SC-691 also pulls INRDY_ high at the rising edge of STROBE_.
- ▶ The data is latched in the SC-691 at the rising edge of STROBE_.

When the microcontroller sets STROBE_ high, the SC-691 sets INRDY_ high to indicate that the SC-691 is not ready to receive any more data.

A) Sequence of events for a single write operation:

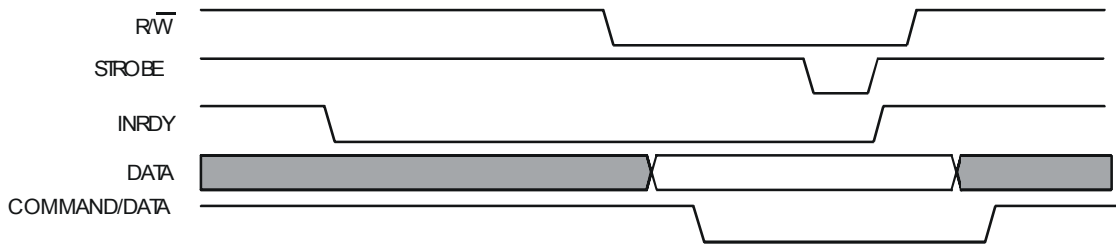

B) Read-Two speech data transfer sequences:

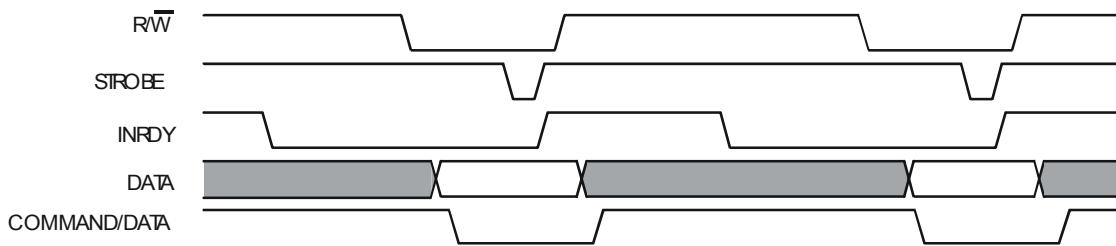

Figure 4: Data Transfer - Write

Absolute Maximum Ratings

Absolute maximum ratings over operating free-air temperature range (unless otherwise noted)†

Supply voltage, V_{DD} (see Note 1)	-0.3 to 7 V	WARNING: Stressing the SC-691 beyond the “Absolute Maximum Ratings” may cause permanent damage. These are stress ratings only. Operation beyond the “Operating Conditions” is not recommended and extended exposure beyond the “Operating Conditions” may affect device reliability.
Supply current, I_{DD} (see Note 2)	35 mA	
Input voltage range, V_I (see Note 1)	-0.3 to $V_{DD} + 0.3$ V	
Output voltage range, V_O (see Note 1)	-0.3 to $V_{DD} + 0.3$ V	
Storage temperature range, T_A	-30°C to 125°C	

NOTES: 1. Unless otherwise noted, all voltages are measured with respect to V_{SS} .
 2. The total supply current includes the current out of all the I/O pins as well as the operating current of the device.

Recommended Operating Conditions

	MIN	MAX	UNIT
Supply voltage (with respect to V_{SS}), V_{DD}	3	5.2	V
CPU clock rate (as programmed), f_{CPU}	64	12,320	kHz
Load resistance between DAC_P and DAC_M , R_{DAC}	32		Ω
Operating free-air temperature, T_A	Device functionality		°C

Timing Requirements

	MIN	MAX	UNIT
$t_{(RESET)}$ Reset_ low pulse width, while V_{DD} is within specified limits	100		ns
$t1_{(WIDTH)}$ Pulse width required prior to a negative transition at pin (PD3 or PD5 interrupt)	2		$1/f_{CPU}$
$t2_{(WIDTH)}$ Pulse width required prior to a positive transition at pin (PD2 or PD4 interrupt)	2		$1/f_{CPU}$

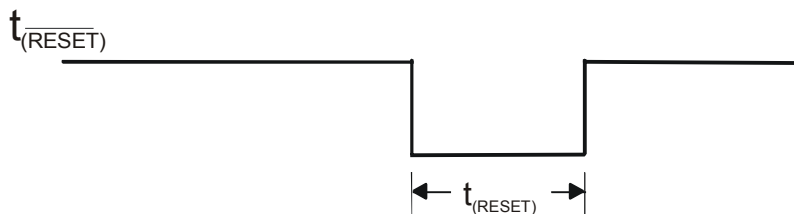

Figure 5: Initialization Timing Diagram

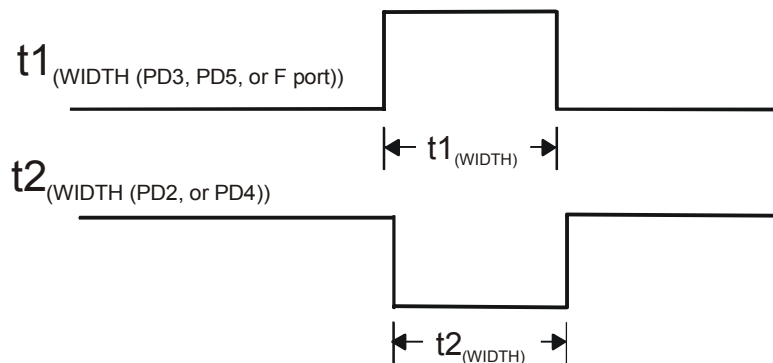

Figure 6: SC-691 External Interrupt Pin Pulse Width Requirements $t1_{WIDTH}$ and $t2_{WIDTH}$

DC Electrical Characteristics, $T_A = 0$ to 70°C

PARAMETER	TEST CONDITIONS	MIN	TYP [§]	MAX	UNIT	
RESET_ Threshold changes	$V_{DD} = 3\text{ V}$	Positive going threshold	2.4		V	
		Negative going threshold	1.8			
		Hysteresis	0.6			
	$V_{DD} = 5.2\text{ V}$	Positive going threshold	3.3		V	
		Negative going threshold	2.9			
		Hysteresis	0.4			
V_{IH} High-level input voltage	$V_{DD} = 3\text{ V}$	2		3	V	
	$V_{DD} = 4.5\text{ V}$	3		4.5		
	$V_{DD} = 5.2\text{ V}$	3.5		5.2		
V_{IL} Low-level input voltage	$V_{DD} = 3\text{ V}$	0		1	V	
	$V_{DD} = 4.5\text{ V}$	0		1.5		
	$V_{DD} = 5.2\text{ V}$	0		1.7		
I_{OH} [¶] High-level output current per pin of I/O port	$V_{DD} = 4.5\text{ V}$	$V_{OH} = 4\text{ V}$		-2	mA	
I_{OL} [¶] Low-level output current per pin of I/O port		$V_{OL} = 0.5\text{ V}$		5	mA	
I_{OH} (DAC) High-level output DAC current		$V_{OH} = 4\text{ V}$		-10	mA	
I_{OL} (DAC) Low-level output DAC current		$V_{OL} = 0.5\text{ V}$		20	mA	
I_{Ikg} Input leakage current	Excludes OSC_{IN}			1	μA	
$I_{(STANDBY)}$ Standby current	RESET is low		0.05	10	μA	
I_{DD} [†] Operating current	$V_{DD} = 4.5\text{ V}$, $F_{CLOCK} = 12.32\text{ MHz}$		15		mA	
$I_{(SLEEP-deep)}$	Supply current	$V_{DD} = 4.5\text{ V}$, DAC off, ARM set, OSC disabled	0.05	10	μA	
$I_{(SLEEP-mid)}$			$V_{DD} = 4.5\text{ V}$, DAC off, ARM set, OSC enabled	40		60
$I_{(SLEEP-light)}$			$V_{DD} = 4.5\text{ V}$, DAC off, ARM clear, OSC enabled	60		100
V_{IO} Input offset voltage	$V_{DD} = 4.5\text{ V}$, $V_{ref} = 1$ to 4.25 V		25	50	mV	
$R_{(PULLUP)}$ F port pullup resistance	$V_{DD} = 5\text{ V}$	70	150		$\text{K}\Omega$ □	
$\Delta f_{(RTO-trim)}$ Trim deviation	$R_{RTO} = 470\text{ K}\Omega$, $V_{DD} = 4.5\text{ V}$, $T_A = 25^\circ\text{C}$, $f_{RTO} = 8.192\text{ MHz}$ (PLL setting = 7 Ch) [‡]		$\pm 1\%$	$\pm 3\%$		
$\Delta f_{(RTO-volt)}$ Voltage deviation	$R_{RTO} = 470\text{ K}\Omega$, $V_{DD} = 3.5$ to 5.2 V , $T_A = 25^\circ\text{C}$, $f_{RTO} = 8.192\text{ MHz}$ (PLL setting = 7 Ch) [‡]			$\pm 1.5\%$		
$\Delta f_{(RTO-temp)}$ Temperature deviation	$R_{RTO} = 470\text{ K}\Omega$, $V_{DD} = 4.5\text{ V}$, $T_A = 0$ to 70°C , $f_{RTO} = 8.192\text{ MHz}$ (PLL setting = 7 Ch) [‡]		± 0.03		$\%/^\circ\text{C}$	
$\Delta f_{(RTO-res)}$ Resistance deviation	$V_{DD} = 4.5\text{ V}$, $T_A = 25^\circ\text{C}$, $R_{(OSC)} = 470\text{ K}\Omega$ at $\pm 1\%$, $f_{RTO} = 8.192\text{ MHz}$ (PLL setting = 7 Ch) [‡]		$\pm 1\%$			

† Operating current assumes all inputs are tied to either V_{SS} or V_{DD} with no input currents due to programmed pullup resistors. The DAC output and other outputs are open circuited.

‡ The best trim value is selected at nominal temperature and voltage but the deviation due to the trim error is ignored.

§ Typical voltage and current measurement taken at 25°C

¶ This parameter cannot exceed 15 mA total per internal V_{DD} pin. Port C and port D share 1 internal V_{DD} . Ports A and G0 are used internally.

External Component Absolute Values

PARAMETER	TEST CONDITIONS	MIN	MAX	UNIT
$R_{(RTO)}$ RTO external resistance	$T_A = 25^\circ\text{C}$, 1% tolerance		470	$\text{K}\Omega$
$C_{(PLL)}$ PLL external capacitance	$T_A = 25^\circ\text{C}$, 10% tolerance		3300	pF

Mechanical Data

LQFP 64 PLASTICQUAD FLATPACK (10x10x1.4 mm)

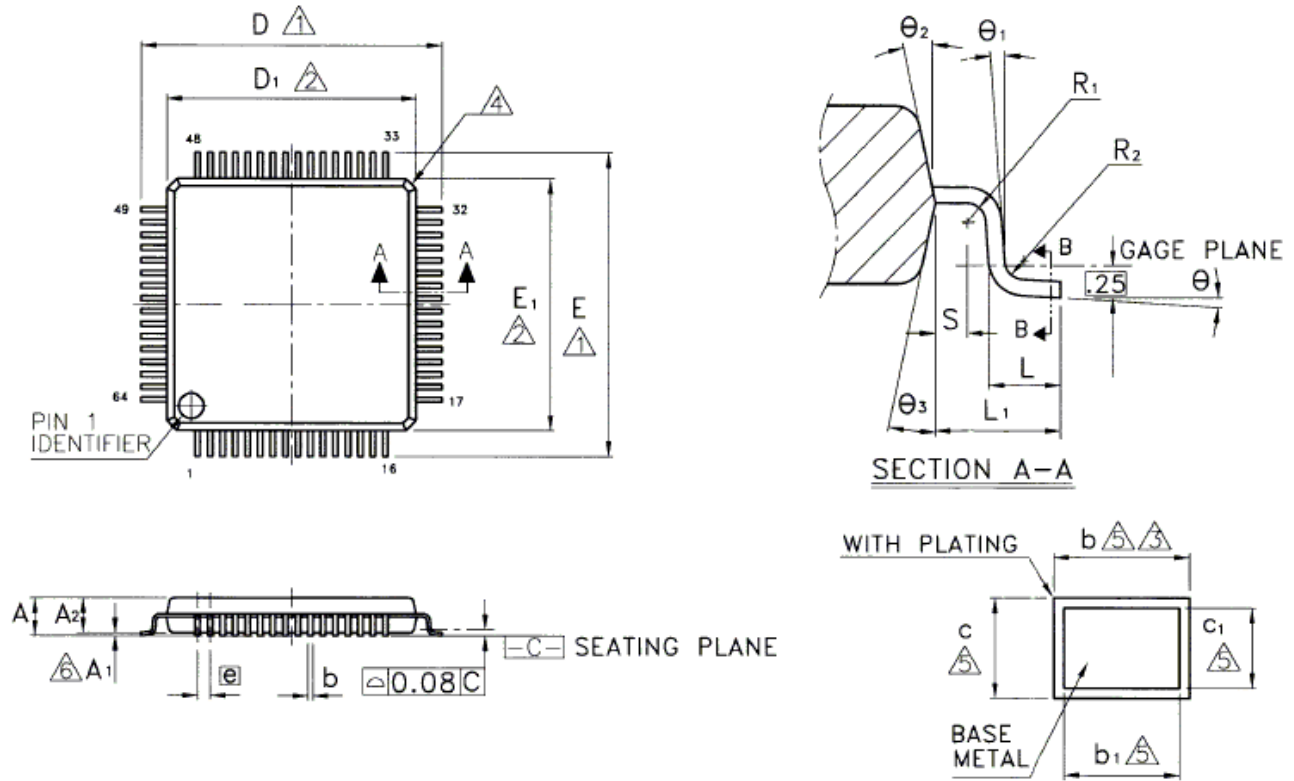

Symbol	Dimension in mm			Dimension in inch		
	Min	Nom	Max	Min	Nom	Max
A	-	-	1.60	-	-	0.063
A1	0.05	-	0.15	0.002	-	0.006
A2	1.35	1.40	1.45	0.053	0.055	0.057
b	0.17	0.22	0.27	0.007	0.009	0.011
b1	0.17	0.20	0.23	0.007	0.008	0.009
c	0.09	-	0.20	0.004	-	0.008
c1	0.09	-	0.16	0.004	-	0.006
D	12.00 BSC			0.472 BSC		
D1	10.00 BSC			0.394 BSC		
E	12.00 BSC			0.472 BSC		
E1	10.00 BSC			0.394 BSC		
⓪	0.50 BSC			0.20 BSC		
L	0.45	0.60	0.75	0.018	0.024	0.030
L1	1.00 REF			0.039 BSC		
R1	0.08	-	-	0.003	-	-
R2	0.08	-	0.20	0.003	-	0.008
S	0.20	-	-	0.008	-	-
□	0°	3.5°	7°	0°	3.5°	7°
□1	0°	-	-	0°	-	-
□2	12° TYP			12° TYP		
□3	12° TYP			12° TYP		

- Notes:
- A. All linear dimensions are in millimeters.
 - B. This drawing is subject to change without notice.
 - C. Falls within JEDEC MS-022

Die Bond-out Coordinates

Die Size = 147.64 x 111.02 Mil

Pad Size = 210 x 210 Mil

Units = Metric

Pad	Pin	X-Axis Min	Y-Axis Min	X-Axis Max	Y- Axis Max
1	1	149.00	2122.80	235.00	2208.80
2	2	149.00	1961.45	235.00	2047.45
3	3	127.40	1805.45	213.40	1891.45
4	4	127.40	1651.45	213.40	1737.45
5	5	127.40	1497.45	213.40	1583.45
6	6	127.40	1343.45	213.40	1429.45
7	7	127.30	1191.05	213.30	1277.05
8	8	127.40	1077.95	213.40	1163.95
9	9	127.30	925.45	213.30	1011.45
10	10	127.30	814.15	213.30	900.15
11	11	127.30	702.85	213.30	788.85
12	12	127.45	555.50	213.45	641.50
13	13	127.30	435.50	213.30	521.50
14	14	127.30	324.20	213.30	410.20
15	15	127.30	212.90	213.30	298.90
16	16	148.00	108.10	234.00	194.10
17	31	3385.20	61.50	3471.20	147.50
18	32	3472.20	172.75	3558.20	258.75
19	33	3472.20	326.75	3558.20	412.75
20	34	3472.20	480.75	3558.20	566.75
21	35	3472.20	634.75	3558.20	720.75
22	36	3472.20	788.75	3558.20	874.75
23	37	3472.20	942.75	3558.20	1028.75
24	38	3472.20	1096.75	3558.20	1182.75
25	39	3472.20	1250.75	3558.20	1336.75
26	40	3472.20	1404.75	3558.20	1490.75
27	41	3472.20	1558.75	3558.20	1644.75
28	42	3472.20	1712.75	3558.20	1798.75
29	43	3472.20	1866.75	3558.20	1952.75
30	44	3450.60	2026.15	3536.60	2112.15
31	45	3517.01	2165.85	3603.01	2251.85
32	46	3517.01	2319.91	3603.01	2405.91
33	47	3517.01	2473.95	3603.01	2559.95
34	48	3516.80	2583.45	3602.80	2669.45
35	49	3149.35	2581.75	3235.35	2667.75
36	64	97.30	2533.65	183.30	2619.65

Ordering Information

Part	Ordering P/N	Shipping P/N	Description
SC-691 DIE	SC691	65-0140-A	Tested, Singulated SC-691 die in waffle pack.
SC-691 LQFP	SC691-L1	65-0139-A	SC-691 64 pin 10x10x1.4mm LQFP

The Interactive Speech™ Product Line

Sensory's **Interactive Speech™** product line makes consumer electronics more intelligent by enabling them to talk and hear with speech synthesis, voice recognition, and other advanced audio and interactive technologies. It is designed for integration into cost-sensitive consumer electronic applications such as home electronics, smart toys, music players and personal communication devices. The hardware line includes the award-winning RSC-4x family of mixed signal processors, the *VR Stamp™* 40-pin DIP module, and the SC-691 music and speech synthesis slave processor. Embedded software options include our *FluentSoft™* Recognizer, which enables speech recognition on non-Sensory processors and DSPs. Sensory's *BlueGenie™* Voice User Interface, the first Voice Recognition and Synthesis option for Bluetooth enabled devices, offers user friendly control of headsets, music players and other BT devices requiring hands-free operation.

RSC Microcontrollers and Tools

The RSC product family contains low-cost 8-bit speech-optimized microcontrollers that are fully integrated and include A/D, pre-amplifier, D/A, RAM, and ROM circuitry. With Sensory's *FluentChip™* firmware, the RSC family offers speech recognition, speaker verification, speech and music synthesis, voice recording and playback, and an entire suite of interactive robotic and sonic networking technologies. The family is supported by a complete suite of evaluation and development toolkits that include the ability to quickly create speaker independent recognition sets in many languages.

Speech Recognition Modules and Tools

The *VR Stamp™* is a complete speech recognition module based on the RSC-4x and is ideal for fast design and easy production. A low-noise audio channel and standardized 40-pin DIP footprint allow rapid prototyping, less debugging, and shorter time to market. The *VR Stamp Toolkit* includes everything needed to get started today, including VR Stamps, Module Programming Board, sample applications, and a complete set of development tools featuring the Python IDE and limited-life C compiler, *QuickSynthesis™ 4* and *Quick T2SI-Lite™* speech tools.

SC6 Slave Processor and Tools

The SC-691 is a standard slave synthesizer that accepts compressed speech data from other microprocessors or microcontrollers and converts it to speech. The chip operates up to 12.32 MIPS, and provides high-quality, low data-rate speech compression and MIDI music synthesis, with unlimited speech duration using external memory. Sensory offers hardware and software tools for analyzing speech files, editing speech data and generating coded speech.

FluentSoft™ Recognizer

The *FluentSoft™* Recognizer is the engine powering the *FluentSoft™* SDK. It provides a noise-robust, large-vocabulary, speaker-independent solution with continuous digit recognition and word-spotting capabilities. This small-footprint software recognizes thousands of words and runs on non-Sensory processors including Intel XScale, TI OMAP, and ARM9, and supports operating systems such as MS Windows, Linux, and Symbian.

BlueGenie™ Voice User Interface

The *BlueGenie* Voice Interface software suite runs on CSR's BC-5 MM Kalimba DSP, and enables manufacturers of Bluetooth products to integrate full voice control and synthetic speech output without the need for visual displays or complex user interfacing. It frees designers to pack functionality onto small form factor Bluetooth devices and answers consumer demand for a truly hands-free experience.

Important notices:

Sensory Incorporated (Sensory, Inc.) reserves the right to make changes, without notice, including circuits, standard cells, and/or software, described or contained herein in order to improve design and/or performance. Sensory, Inc. assumes no responsibility nor liability for the use of any of these products, conveys no license or title under any patent, copyright, or mask-work right to these products, and makes no representations or warranties that these products are free from patent, copyright, or mask-work right infringement, unless otherwise specified. Applications that are described herein for any of these products are for illustrative purposes only. Sensory, Inc. makes no representation or warranty that such applications will be suitable for the specified use without further testing or modification.

Safety Policy:

Sensory, Inc. products are not designed for use in any systems where malfunction of a Sensory, Inc. product can reasonably be expected to result in a personal injury, including but not limited to life support appliances and devices. Sensory, Inc. customers using or selling Sensory Incorporated products for use in such applications do so at their own risk and agree to fully indemnify Sensory, Inc. for any damages resulting from such improper use or sale.



575 N. Pastoria Ave., Sunnyvale, CA 94085
Tel: (408) 625-3300 Fax: (408) 625-3350

© 2001-2008 SENSORY, INC.

ALL RIGHT RESERVED.

Sensory is registered by the U.S. Patent and Trademark Office.

All other trademarks or registered trademarks are the property of their respective owners.